



versatile

valuable

Work productively

Increase your productivity with this variable reach forklift. Save time by quickly loading and unloading flatbed trucks from one side. Increase inventory storage by reducing truck loading areas.

The Teletruk, available in 2WD or full-time 4WD, offers outstanding adverse conditions performance.

The Teletruk features the Tier 4 Kohler KDI 2504 engine which requires no exhaust aftertreatment (DPF) maximizing productivity with no downtime for maintenance. 

The Teletruk can be more than a forklift. Easily change from carriage and forks to bucket or any attachment, using the quick disconnect system.

JCB Teletruk
variable reach
materials handler

 **SELICK**

JCB Teletruk Variable Reach Forklifts

Lift capacities of 6,000 and 7,000 lbs @ 24" load centre

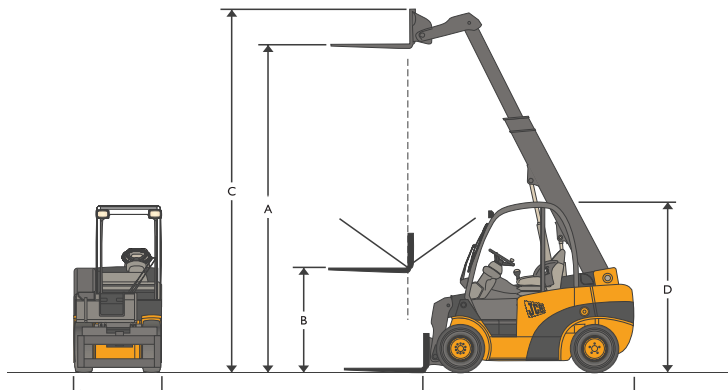

Model	Ref	TLT30DHL	TLT35D	TLT35D 4x4
Lift capacity @ 24 in load centre		6 000 lbs	7 000 lbs	7 000 lbs
Lift capacity @ maximum forward reach		1 089 lbs	3 250 lbs	3 250 lbs
Maximum reach with boom horizontal		130 in	95.6 in	96.4 in
Lift height	A	16 ft 10 in	14 ft	14 ft
Free lift (standard)	B	48 in	47.6 in	53 in
Height boom extended	C	18 ft 8 in	16 ft 3 in	16 ft 5 in
Height of overhead guard (std/low)	D	88.5/83	88.5/83 in	90.5/86.6 in
Length to fork face	F	133 in	118 in	126 in
Maximum width	P	50 in	50 in	55 in
Underclearance		6.0 in	6.0 in	7.0 in
Turning radius		114 in	114 in	138 in
Aisle width 90° stacking		184 in	184 in	207 in
Engine type		Diesel	Diesel	Diesel
Engine model		Kohler	Kohler	Kohler
Gross engine output		62 hp	62 hp	62 hp
Rated rpm		2 600	2 600	2 600
Weight unladen		11 860 lbs	11 243 lbs	12 125 lbs

Because of our constant dedication to product improvement, all specifications are subject to change without notice.

— All JCB Teletruk meets or exceeds all ANSI B56.1 safety standards. —

Lift capacity @ other side of truck/trailer

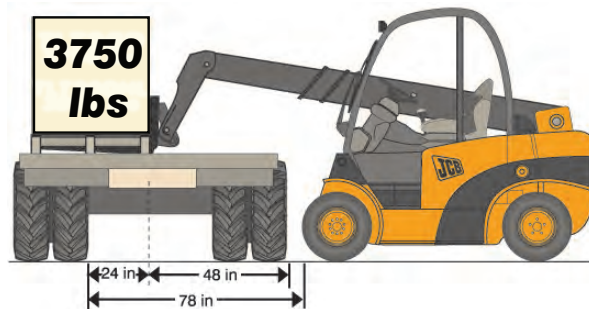

Sellick Equipment Limited
P.O. Box 1000/358 Erie Street North
Harrow, Ontario, Canada • N0R 1G0
519-738-2255 • sellick@mnsi.net
www.sellickequipment.com



Sold and serviced by:

Standard features

The versatile Teletruk with **extended forward reach** capability allows **quick** and convenient unloading or loading of flatbed trucks from one side. The 111° carriage tilt coupled with quick disconnects allows easy changing of attachments. Equipped with a powerful, **Tier 4 Kohler engine**, these machines use less fuel while providing the power necessary to get all the work done. And, with no diesel aftertreatment required (DPF), downtime for maintenance is minimized while maximizing productivity. With their small dimensions and tight turning radius, the multi-purpose Teletruk is a perfect companion to handle any application.

Maximum lift capacity

TLT30DHL: 6 000 lbs
TLT35 Series: 7 000 lbs

Engine

TLT30DHL & TLT35 Series:

Kohler KDI 2504, 2.4 L, 62 hp, Tier 4 Final, Diesel.

Transmission

Hydrostatic transmission with torque converter response.

Operator's Enclosure

Comfortable and ergonomically-designed operator's enclosure meets North American safety standards for roll-over protection (ROPS) and falling object protection (FOPS).

Boom

"Slimline" boom allows maximum visibility of the forks. Wear pad design eliminates chain and roller maintenance of masted machines.

Standard equipment

- Fully adjustable suspension seat with retractable seatbelt
- Flow divider "diff-lock" for traction control on 2WD units
- Lighting kit includes two headlights, amber strobe and one rear light
- Hose burst check valves on tilt, lift and extension cylinder circuits
- Full-time all-wheel drive on 4WD units
- Back up alarm