

CROWN

ET 4000 SERIES

Specifications

Rider Stacker



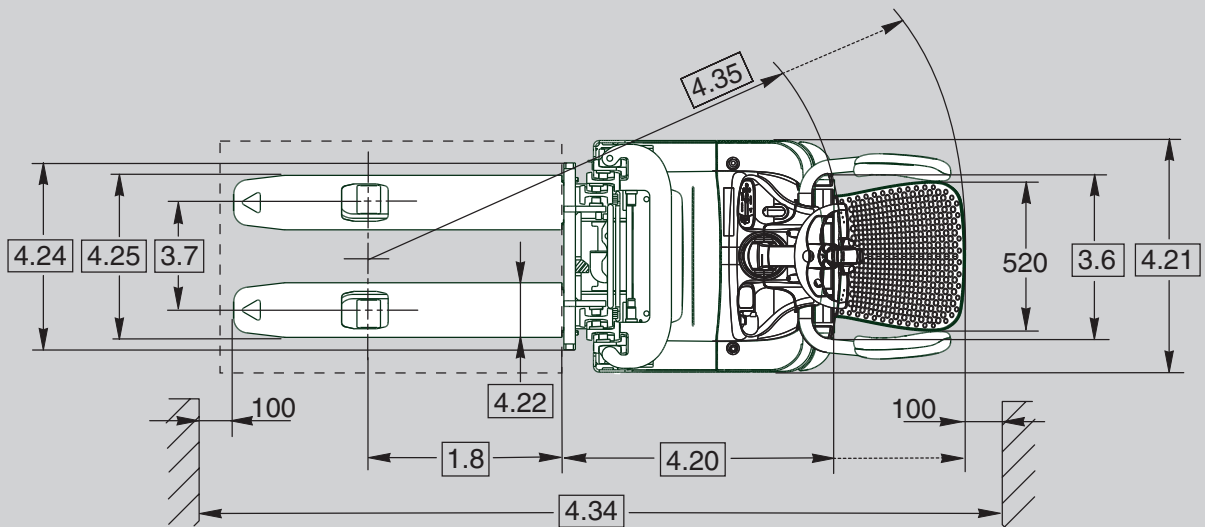
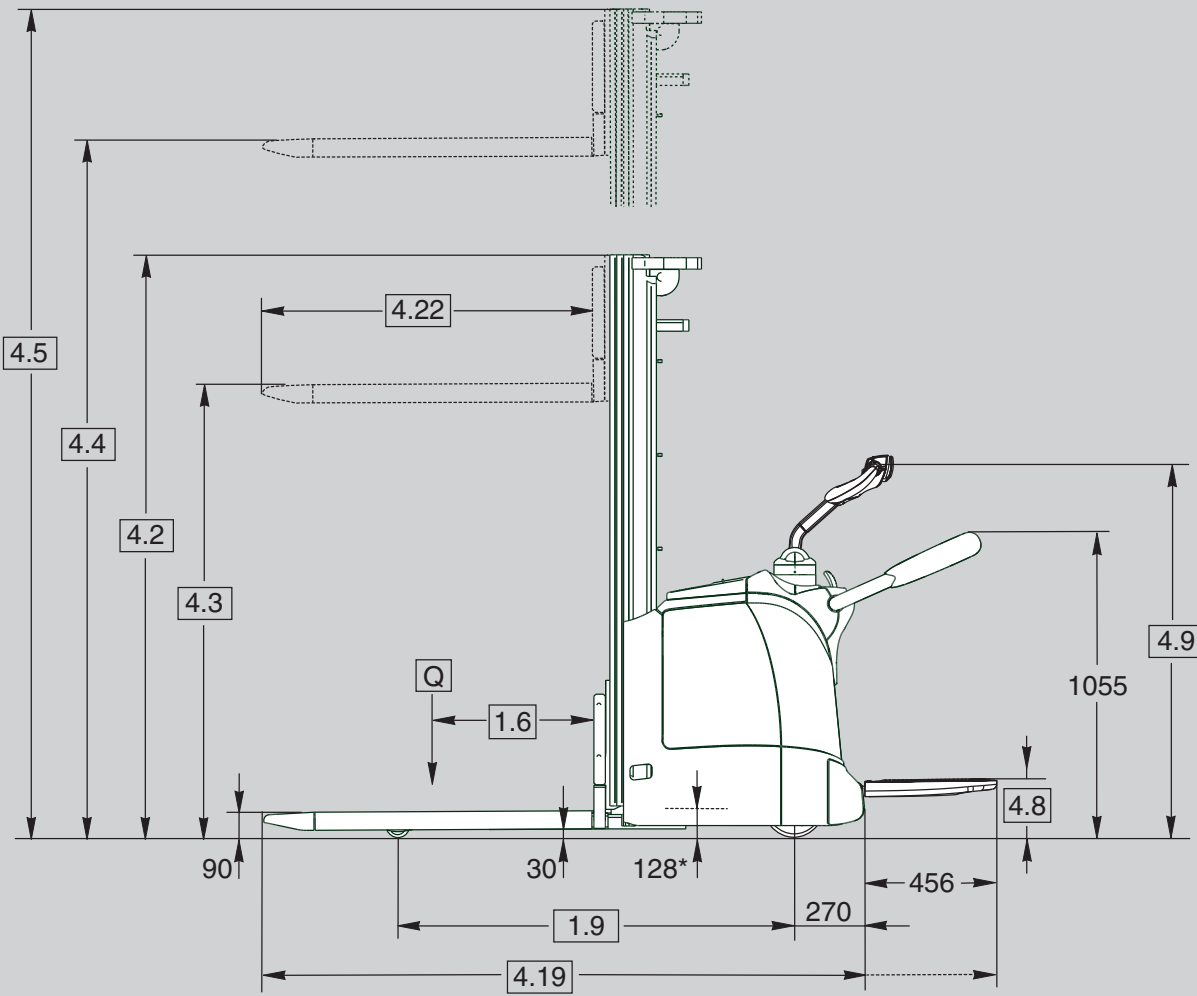

* battery roll out height

General Information	1.1	Manufacturer	Crown Equipment Corporation					
	1.2	Model			ET 4000 – 1.2	ET 4000 – 1.4	ET 4000 – 1.6	
	1.3	Power			electric			
	1.4	Operator Type			stand-on			
	1.5	Load Capacity	Q	t	1.2	1.4	1.6	
	1.6	Load Centre	c	mm	600			
	1.8	Load Distance ¹	x	mm	675	670	679	
	1.9	Wheel Base ^{1 2}	y	mm	1239		1279	
	Weights	2.1	Weight	less battery	kg	see table 1	see table 2	see table 3
2.2		Axle Load	w. load, front / rear	kg	see table 1	see table 2	see table 3	
2.3		Axle Load	w.o. load, front / rear	kg	see table 1	see table 2	see table 3	
Tyres	3.1	Tyre Type			Vulkollan			
	3.2	Wheel Size ³	front	mm	Ø 230 x 70			
	3.3	Wheel Size	rear	mm	1x Ø 82 x 100		2x Ø 82 x 60	
	3.4	Additional Wheels	castor wheel	mm	2x Ø 125 x 54			
	3.5	Wheels	no. (x=driven) front/rear		1x + 2/2		1x + 2/4	
	3.6	Track Width ⁴	front	b10	mm	542		
	3.7	Track Width	rear	b11	mm	390	395	
Dimensions	4.2	Mast	collapsed height	h1	mm	see table 1	see table 2	see table 3
	4.3	Free Lift		h2	mm	see table 1	see table 2	see table 3
	4.4	Lift Height		h3+h13	mm	see table 1	see table 2	see table 3
	4.5	Mast	extended height	h4	mm	see table 1	see table 2	see table 3
	4.8	Operator Stand Height				186		
	4.9	Tiller Arm Height	in drive position min./max.	h14	mm	1056 / 1359		
	4.15	Fork Height	lowered	h13	mm	90		
	4.19	Overall Length ²	platform up, TL/TF/TT	l1	mm	1965 / 1965 / 1983	1970 / 1970 / 1988	1995 / 1995 / 2019
			platform down, TL/TF/TT	l1	mm	2421 / 2421 / 2439	2426 / 2426 / 2444	2451 / 2451 / 2475
	4.20	Headlength ²	platform up, TL/TF/TT	l2	mm	815 / 815 / 833	820 / 820 / 838	845 / 845 / 869
			platform down, TL/TF/TT	l2	mm	1271 / 1271 / 1289	1276 / 1276 / 1294	1301 / 1301 / 1325
	4.21	Overall Width		b1	mm	800		
	4.22	Fork Dimension	standard	thxwxl	mm	60 x 186 x 1150	60 x 190 x 1150	
	4.24	Fork Carriage Width		b3	mm	650		
	4.25	Width Across Forks		b5	mm	560	565	
	4.32	Ground Clearance	centre wheel base	m2	mm	30		
	4.34	Working Aisle Width ^{2 5}	800x1200 length, platform up	Ast	mm	2394	2398	2431
800x1200 length, platform down			Ast	mm	2825	2829	2862	
4.35	Turning Radius ^{1 2}	platform up	Wa	mm	1534	1534	1574	
		platform down	Wa	mm	1965	1965	2005	
Performance	5.1	Travel Speed	w./w.o. load	km/h	8 / 9	7.7 / 9	7.5 / 9	
	5.2	Lift Speed	w./w.o. load	m/s	0.16 / 0.24	0.14 / 0.24	0.12 / 0.24	
	5.3	Lowering Speed	w./w.o. load	m/s	0.36 / 0.28			
	5.8	Max. Gradeability	w./w.o. load 5 min. rating	%	10 / 16	9 / 16	8 / 16	
	5.10	Service Brake			electric			
Motors	6.1	Traction Motor	rating at S2 60 min. / H-class	kW	3.0			
	6.2	Lift Motor	rating at S3 10 %	kW	3.0			
	6.3	Battery	acc. to DIN 43535			B		
		Max. Battery Box Size ⁶		lxwxh	mm	212 x 624 x 627 (284 x 624 x 627)		
	6.4	Battery Voltage ⁶	nominal capacity 5h rating		V/Ah	24 / 250 (375)		
6.5	Battery Weight ⁶			kg	212 (309)			
Misc.	8.1	Type Controller	drive		AC-transistor			
	8.4	Sound Level	acc. to EN 12053		dB(A)	≤ 70		

¹ add 100 mm with electric steering² add 72 mm for larger battery compartment³ Ø 250 x 75 mm with electric steering⁴ subtract 9 mm with electric steering⁵ add 24 mm with electric steering⁶ with optional larger battery compartment use values in brackets

Table 1 Mast Chart

1.2 Model				ET 4000 - 1.2															
Mast Type				TL					TF					TT					
2.1	Weight *	less battery	kg	911	933	953	977	1003	921	942	962	985	1010	1043	1062	1075	1090	1107	
2.2	Axle Load 250 Ah	w. load	front	kg	941	956	970	986	1004	947	962	976	992	1009	1013	1026	1035	1045	1057
			rear	kg	1382	1389	1395	1403	1411	1386	1392	1398	1405	1413	1442	1448	1452	1457	1462
2.3	Axle Load 250 Ah	w.o. load	front	kg	849	865	879	895	913	856	871	885	901	918	940	953	962	972	984
			rear	kg	274	280	286	294	302	277	283	289	296	304	315	321	325	330	335
2.2	Axle Load 375 Ah	w. load	front	kg	1005	1019	1033	1048	1065	1012	1025	1038	1053	1070	1074	1087	1095	1105	1116
			rear	kg	1434	1442	1448	1457	1466	1437	1445	1452	1460	1468	1497	1504	1508	1513	1519
2.3	Axle Load 375 Ah	w.o. load	front	kg	919	933	946	962	979	926	939	952	967	984	1004	1017	1025	1035	1046
			rear	kg	320	328	335	343	352	323	331	338	346	354	367	374	378	383	389
4.2	Mast	collapsed height	h1	mm	1770	1980	2180	2420	2670	1770	1980	2180	2420	2670	1845	1980	2140	2220	2370
4.3	Free Lift **		h2	mm	180					1290	1500	1690	1940	2190	1360	1500	1660	1735	1870
4.4	Lift Height		h3+h13	mm	2440	2860	3260	3740	4240	2540	2960	3360	3840	4340	4000	4440	4750	5000	5400
4.5	Mast ***	extended height	h4	mm	2920	3350	3750	4220	4720	3020	3450	3850	4320	4820	4480	4930	5240	5480	5880

Table 2 Mast Chart

1.2 Model				ET 4000 - 1.4															
Mast Type				TL					TF					TT					
2.1	Weight *	less battery	kg	930	953	975	1001	1029	940	963	984	1009	1036	1063	1083	1097	1113	1131	
2.2	Axle Load 250 Ah	w. load	front	kg	957	973	988	1006	1025	964	980	994	1012	1030	1028	1042	1051	1062	1074
			rear	kg	1585	1592	1599	1607	1616	1588	1595	1602	1609	1618	1647	1654	1658	1663	1669
2.3	Axle Load 250 Ah	w.o. load	front	kg	856	872	887	905	925	863	879	894	911	930	948	962	971	982	994
			rear	kg	286	293	300	308	316	289	296	302	310	318	327	334	338	343	349
2.2	Axle Load 375 Ah	w. load	front	kg	1021	1036	1050	1067	1085	1027	1042	1056	1072	1090	1086	1100	1109	1120	1132
			rear	kg	1637	1645	1653	1662	1672	1641	1649	1656	1665	1674	1705	1712	1716	1721	1727
2.3	Axle Load 375 Ah	w.o. load	front	kg	926	941	955	972	990	932	947	961	977	995	1010	1024	1033	1044	1056
			rear	kg	332	340	348	357	367	336	344	351	360	369	381	388	392	397	403
4.2	Mast	collapsed height	h1	mm	1770	1980	2180	2420	2670	1770	1980	2180	2420	2670	1845	1980	2140	2220	2370
4.3	Free Lift **		h2	mm	180					1290	1500	1690	1940	2190	1360	1500	1660	1735	1870
4.4	Lift Height		h3+h13	mm	2440	2860	3260	3740	4240	2540	2960	3360	3840	4340	4000	4440	4750	5000	5400
4.5	Mast ***	extended height	h4	mm	2920	3350	3750	4220	4720	3020	3450	3850	4320	4820	4480	4930	5240	5480	5880

Table 3 Mast Chart

1.2 Model				ET 4000 - 1.6															
Mast Type				TL					TF					TT					
2.1	Weight *	less battery	kg	989	1019	1049	1079	1114	1005	1035	1062	1095	1130	1170	1196	1214	1235	1259	
2.2	Axle Load 250 Ah	w. load	front	kg	1034	1055	1076	1097	1121	1045	1066	1085	1108	1132	1127	1146	1159	1174	1191
			rear	kg	1767	1776	1785	1794	1805	1772	1781	1789	1799	1810	1854	1862	1867	1873	1880
2.3	Axle Load 250 Ah	w.o. load	front	kg	905	926	947	968	993	916	937	956	979	1004	1028	1047	1060	1075	1092
			rear	kg	296	305	314	323	333	301	310	318	328	338	353	361	366	372	379
2.2	Axle Load 375 Ah	w. load	front	kg	1095	1115	1135	1155	1178	1105	1125	1143	1165	1188	1184	1202	1214	1228	1244
			rear	kg	1822	1832	1842	1852	1864	1828	1838	1847	1858	1870	1913	1922	1928	1935	1943
2.3	Axle Load 375 Ah	w.o. load	front	kg	973	993	1013	1033	1056	983	1003	1021	1043	1066	1090	1108	1120	1134	1150
			rear	kg	344	354	364	374	386	350	360	369	380	392	407	416	422	429	437
4.2	Mast	collapsed height	h1	mm	1770	1980	2180	2420	2670	1770	1980	2180	2420	2670	1845	1980	2140	2220	2370
4.3	Free Lift **		h2	mm	180					1290	1500	1690	1940	2190	1360	1500	1660	1735	1870
4.4	Lift Height		h3+h13	mm	2440	2860	3260	3740	4240	2540	2960	3360	3840	4340	4000	4440	4750	5000	5400
4.5	Mast ***	extended height	h4	mm	2920	3350	3750	4220	4720	3020	3450	3850	4320	4820	4480	4930	5240	5480	5880

* add 40 kg for 375 Ah battery compartment

** with load backrest subtract 750 mm for TF and TT

*** with load backrest add 750 mm

all data apply to mechanical steering only

Standard Equipment

1. The X10® Control Handle places all truck functions at the operator's fingertips
2. Proportional lifting/lowering provided by a low-noise hydraulic system
3. e-GEN® Braking System offers regenerative and frictionless electric braking. Mechanical braking applies only as parking brake.
4. Crown Access 1 2 3® Comprehensive System Control
 - LCD display
 - Hour meter
 - Keyless start up with PIN code
 - Start up and run time diagnostics
 - Battery discharge indicator and lift interrupt
 - 3 selectable traction performance profiles
 - Onboard diagnostics with real time trouble-shooting capabilities
5. Crown maintenance free 3-phase (AC) traction motor
6. CAN-Bus technology
7. Centre mounted tiller
8. Electric power disconnect push button
9. Ramp hold
10. Vulkollan drive tyre, castor wheel(s) and load wheels
11. Single load wheels (1.2 t and 1.4 t), tandem load wheels (1.6 t)
12. Heavy-duty dual castor wheels
13. Heavy-duty chassis with 8 mm thick steel skirt
14. Easily removable steel covers
15. Hinged steel top battery cover for easy battery access
16. Plexiglas mast guard
17. 250 Ah DIN battery compartment
18. Battery connector DIN 160A
19. Sealed electrical Deutsch connectors
20. Foldable platform
21. Advanced platform suspension
22. Soft floor mat with integrated presence sensor
23. Heavy-duty side restraints with soft side pads and quick-exit feature

Optional Equipment

1. Intelligent Electronic Steering System
 - Selectable performance profiles for speed reduction on curves

- Tactile feedback feature analyses operational conditions and adjusts steering force for optimised control
 - 3-phase (AC) steering motor
2. 375 Ah battery compartment
 3. Battery roll out (right hand side, forks first direction)
 4. Onboard charger (lift out only)
 5. Battery connector SBE 160 red / SB 175 red / SB 175 grey
 6. Foldable platform without side restraints (mechanical steering only)
 7. Rubber or Supertrac drive tyre
 8. Tandem load wheels (1.2 t and 1.4 t)
 9. Fork length and spread options
 10. 1200 mm high load backrest
 11. Key switch or key pad
 12. Freezer conditioning
 13. InfoLink® ready
 14. Work Assist accessory tube
 15. Work Assist Accessories
 - Storage pockets
 - Scan gun holder
 - Medium and large clipboards
 - Beverage holder
 16. Metal mast grill
 17. Flashing beacon
 18. Travel alarm
 19. 12V clean power supply
 20. 24V power supply
 21. Special paint
 22. Lithium-Ion Battery Ready

Electric System / Battery

24 volt electrical system with nominal battery capacities from 250 Ah to 375 Ah is managed by Crown's Access 1 2 3 Comprehensive System Control. Virtually maintenance-free Crown AC traction motor provides strong acceleration and control at any speed. Sensors monitor functional parameters including steering, load weight, height, drive mode and speed and adjust operational settings automatically to suit conditions.

Power Unit

The rugged power unit features a reinforced 8 mm thick skirt to protect drive unit and castor components. Removable steel covers all around ensure internal components are protected against impacts yet easily accessible for service. On the inside a Crown-built AC traction motor and a low-noise cast iron gearbox provide reliable power.

Operator Area and Controls

The ET 4000 Series incorporates numerous design features to improve operator comfort and productivity.

The folding FlexRide platform reduces shock transfer to the operator. The lifetime platform suspension never requires adjustment and features solid state induction switches to avoid reliability issues caused by contaminants.

Heavy-duty side restraints feature 50 mm heavy-wall steel tubing and rugged C-clamp mounting system. Soft polyurethane side pads are positioned for excellent support and comfort. The quick-exit feature (patent pending) allows the restraints to swing up for faster access to the load.

The centre mounted X10 Control Handle, designed for simultaneous operation of all functions with one hand, improves side-stance operation for maximum visibility in both driving directions and positions the operator in a safe distance to the power unit even with the tiller turned 90° in pedestrian mode. An ergonomic forward/reverse thumb wheel allows for precise manoeuvring. The hand grips are urethane covered for insulation from cold and vibration with integrated horn buttons for easy activation.

A rabbit/turtle switch incorporates two levels of programmable travel performance so operators can select the setting that matches their experience level or application requirements. Available electronic steering improves manoeuvrability and responsiveness, even with heavy loads. Electronic steering combined with speed control on curves, safely delivers top driving performance.

Proportional lift and lowering allows easy and precise positioning of loads. The fast responsiveness and speeds of the lifting and lowering functions are designed to ensure high efficiency in all applications and all this together at a low noise level.

Access 1 2 3® Comprehensive System Control

Crown's Access 1 2 3 technology provides optimum performance and control by offering a communications interface for the operator and service engineer, intelligent coordination of lift truck systems and simplified service with advanced diagnostics. The display includes a full featured on-board service tool allowing service engineers to actively view inputs and outputs during truck operation. No laptop or service terminal is required. Event code history, including the last 16 events, is accessible through the display. The display provides a convenient interface for operators, keeping them informed (hour meter, BDI, operator messages, service codes) of any changes impacting truck performance and allowing them to choose from three performance profiles when enabled. Performance tuning can be accessed at the display to customise truck performance for specific applications or operator requirements. In addition, up to 25 PIN codes can be assigned to individual operators and matched to one of the pre-programmed performance profiles if desired.

e-GEN® Braking System

The power of the high-torque AC traction motor is used to stop the truck and keep it static until a travel input is requested, even when operating on a gradient. This system eliminates adjustments and wear points for a lifetime of maintenance free use. An automatic parking brake activates if the truck is stopped and the operator leaves the platform or power is disconnected.

Safety Regulations

Conforms to European safety standards. Dimensions and performance data given may vary due to manufacturing tolerances. Performance is based on an average size vehicle and is affected by weight, condition of truck, how it is equipped and the conditions of the operating area. Crown products and specifications are subject to change without notice.

