

CROWN

DS DT SERIES

Specifications

Double Stacker



| | | Crown Equipment Corporation | | | | | | | |
|---------------------|----------------------------|--|--------------------------------|-------------|---------------|------------------|-----------------|-------------|--|
| | | | | DS 3040-2.0 | DT 3040-2.0 | | | | |
| General Information | 1.1 | Manufacturer | Crown Equipment Corporation | | | | | | |
| | 1.2 | Model | platform type | | | without platform | | | |
| | | | steering type | | | mechanical | | | |
| | 1.3 | Power | | | electric | | | | |
| | 1.4 | Operator Type | | | pedestrian | | | | |
| | 1.5 | Load Capacity * | Q | t | 2.0 | | | | |
| | 1.6 | Load Centre | c | mm | 600 | | | | |
| | 1.8 | Load Distance | initial lift raised / lowered | x | mm | 904 / 976 | 875 / 940 | | |
| | 1.9 | Wheel Base | initial lift raised / lowered | y | mm | 1501 / 1573 | 1521 / 1589 | 1593 / 1661 | |
| Tyres | 3.1 | Tyres Type | | | Vulkollan | | | | |
| | 3.2 | Wheel Size | front | mm | Ø 250 x 85 | Ø 230 x 70 | | | |
| | 3.3 | Wheel Size | rear | mm | Ø 82 x 100 | Ø 82 x 110 | | | |
| | 3.4 | Additional Wheels | castor wheel | mm | Ø 90 x 50 | Ø 125 x 54 | | | |
| | 3.5 | Wheels | number (x=driven) front/rear | | | 1x + 2/2 | | | |
| | 3.6 | Track Width | front | b10 | mm | 478 | 512 | | |
| | 3.7 | Track Width | rear | b11 | mm | 374 | 370 | | |
| Dimensions | 4.6 | Initial Lift | | h5 | mm | 120 | 125 | | |
| | 4.9 | Tiller Arm Height | in drive position min./max. | h14 | mm | 780 / 1197 | 960 / 1460 | | |
| | 4.15 | Fork Height | lowered | h13 | mm | 89 | | | |
| | 4.19 | Overall Length | initial lift raised / lowered | l1 | mm | 1979 / 1995 | 1986 / 1968 | 2058 / 2040 | |
| | 4.20 | Headlength | initial lift raised / lowered | l2 | mm | 772 / 789 | 836 / 818 | 908 / 890 | |
| | 4.21 | Overall Width | | b1 | mm | 712 | 744 | | |
| | | | standard | thxwxl | mm | 60 x 186 x 1190 | 60 x 186 x 1150 | | |
| | 4.24 | Fork Carriage Width | optional length | l | mm | 650 | | | |
| | 4.25 | Width Across Forks | | b5 | mm | 560 / 570 | 560 | | |
| | 4.32 | Ground Clearance | centre of wheelbase | m2 | mm | 27 | 29 | | |
| 4.34 | Working Aisle Width | 800x1200 mm initial lift raised / lowered | Ast | mm | 2388 / 2418 | 2420 / 2478 | 2492 / 2550 | | |
| 4.35 | Turning Radius | initial lift raised / lowered | Wa | mm | 1703 / 1765 | 1720 / 1778 | 1792 / 1850 | | |
| Performance | 5.1 | Travel Speed | w. / w.o. load | | km/h | 5.9 / 6.0 | 6.0 / 6.0 | | |
| | 5.2 | Lift Speed | w. / w.o. load | | m/s | 0.13 / 0.23 | 0.18 / 0.30 | | |
| | 5.3 | Lowering Speed | w. / w.o. load | | m/s | 0.19 / 0.21 | 0.30 / 0.30 | | |
| | 5.8 | Max. Gradeability | w. / w.o. load, 5 min. rating | | % | 10 / 25 | 6 / 15 | | |
| | 5.10 | Service Brake | | | | electric | | | |
| Motors | 6.1 | Traction Motor | rating at S2 60 min. / H-class | | kW | 1.5 | 3.0 | | |
| | 6.2 | Lift Motor | rating at S3 10% | | kW | 1.3 | 2.2 | | |
| | 6.3 | Battery | acc. to DIN 43535 | lxwxh | mm | B | | | |
| | | Max. Battery Box Size | | lxwxh | mm | 212 x 624 x 627 | 284x624x627 | | |
| | 6.4 | Battery Voltage | nominal capacity 5h rating | | V/Ah | 24 / 250 | 24 / 375 | | |
| 6.5 | Battery Weight | | | kg | 212 - 230 | 270 - 324 | | | |
| 8.1 | Type Controller | drive | | | AC-transistor | | | | |
| 8.4 | Sound Level | acc. to EN 12053 | | dB(A) | 69 | 59 | | | |

* as double stacker 1000 kg + 1000 kg, as pallet truck 2000 kg and as stacker 1000 kg

Mast

| | | DS 3040-2.0 | | | | | DT 3040-2.0 | | | | | |
|------------|------------------|--------------------|------------------|--------|------|-------------|-------------|-------------|-------------|-------------|-------------|-------------|
| | | | | TL | TL | | TL | | TF | | | |
| Weights | 1.2 | Model | | | | | | | | | | |
| | | Mast Type | | | | | | | | | | |
| | 2.1 | Weight | less battery | | kg | 740 | 810 | 840 | 830 | 860 | 950 | |
| | 2.2 | Axle Load | w. load | front | kg | 1075 | 1225 | 1255 | 1245 | 1275 | 1320 | |
| rear | | | | kg | 1880 | 1835 | 1865 | 1855 | 1885 | 1930 | | |
| 2.3 | Axle Load | w.o. load | front | kg | 710 | 875 | 905 | 895 | 925 | 970 | | |
| | | | rear | kg | 245 | 185 | 215 | 205 | 235 | 280 | | |
| Dimensions | 4.2 | Mast | collapsed height | h1 | mm | 1598 | 1698 | 1270 | 1430 | 1270 | 1430 | 1740 |
| | 4.3 | Free Lift | | h2 | mm | 240 | - | - | - | - | 1355 | |
| | 4.4 | Lift Height | | h3+h13 | mm | 2100 | 2300 | 1670 | 2100 | 1670 | 2100 | 2600 |
| | 4.5 | Mast | extended height | h4 | mm | 2497 | 2697 | 2100 | 2500 | 2100 | 2500 | 3025 |

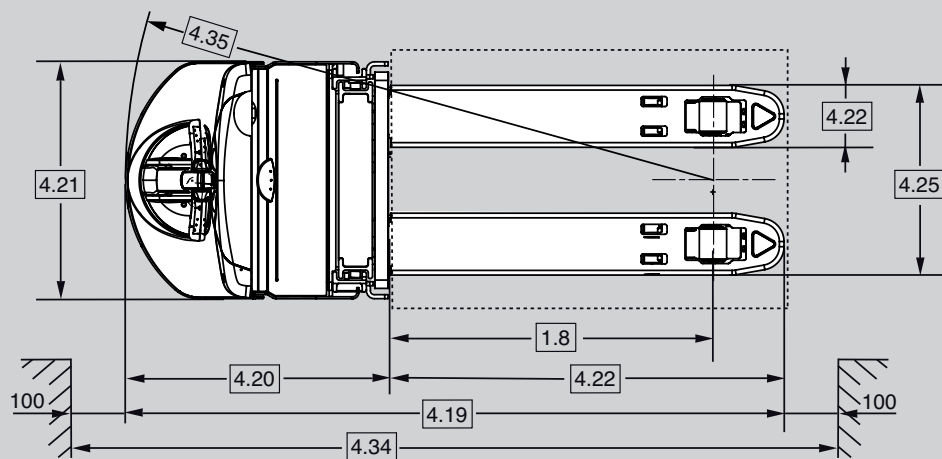
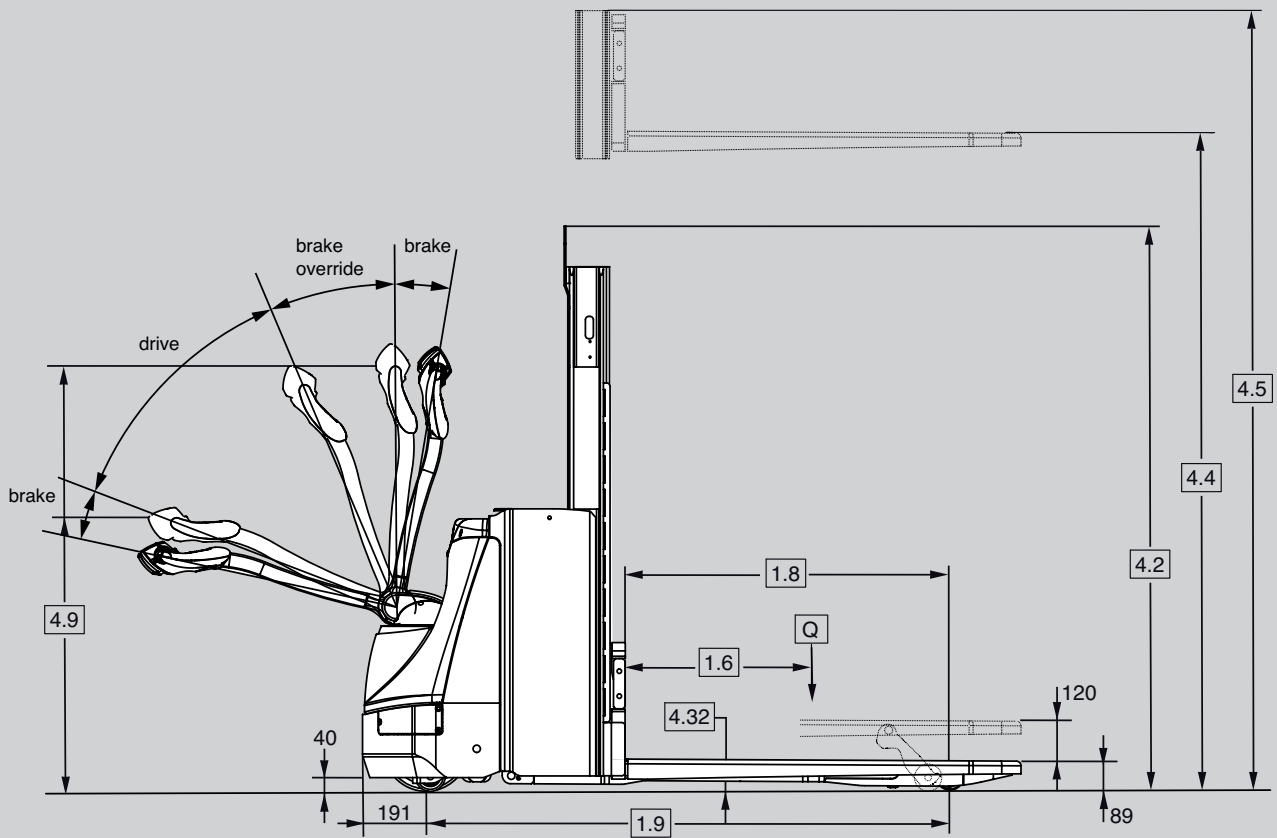

DT 3040-2.0 without platform
mechanical steering

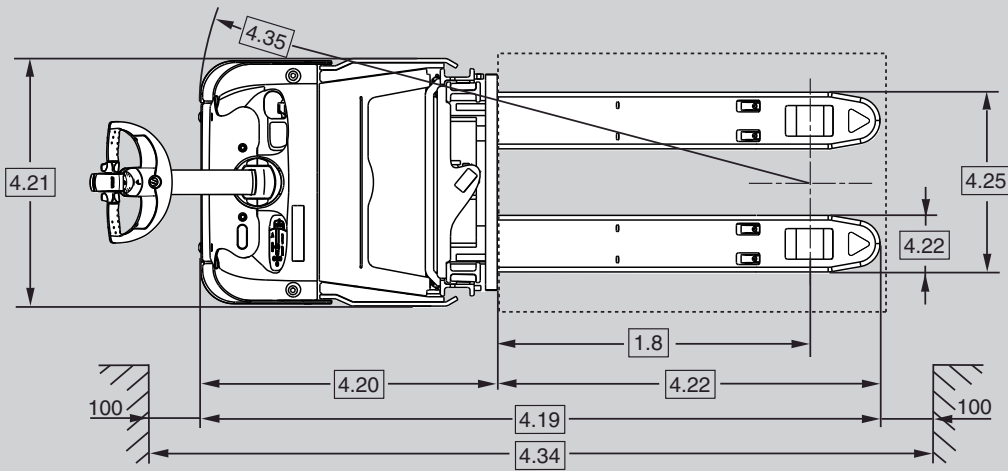
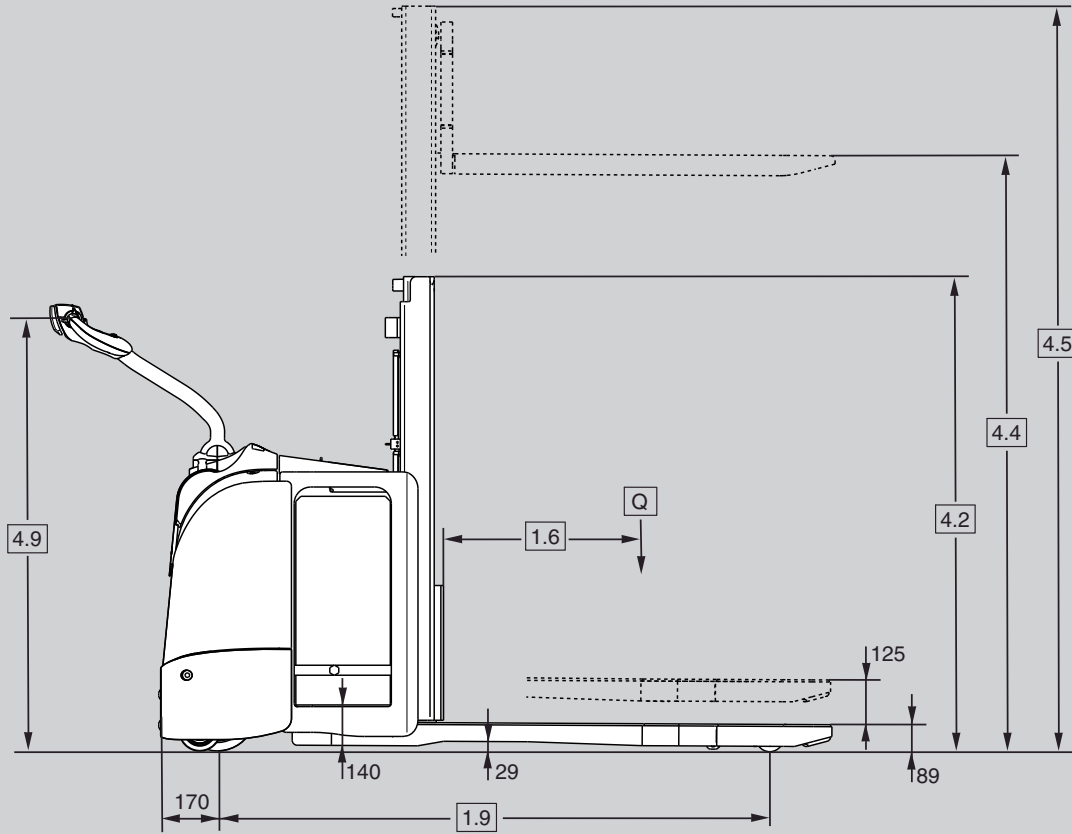

| | | | | | | | | | | | | |
|---------------------|-------------------------------|---------------------------------|--------------------------------|--------|---------------|-----------------------|------------|------------|------------|-------------------|------------|------------|
| General Information | 1.1 | Manufacturer | Crown Equipment Corporation | | | | | | | | | |
| | 1.2 | Model | platform type | | | DT 3040-2.0 | | | | foldable platform | rear entry | side entry |
| | | | steering type | | | mechanical | electric | mechanical | electric | | | |
| | 1.3 | Power | | | | electric | | | | | | |
| | 1.4 | Operator Type | | | | pedestrian / stand-on | | | stand-on | | | |
| | 1.5 | Load Capacity * | | Q | t | 2.0 | | | | | | |
| | 1.6 | Load Centre | | c | mm | 600 | | | | | | |
| | 1.8 | Load Distance | initial lift raised / lowered | x | mm | 875 / 940 | | | | | | |
| | 1.9 | Wheel Base | initial lift raised / lowered | y | mm | 1593 / 1661 | | | | | | |
| Tyres | 3.1 | Tyres Type | | | | Vulkollan | | | | | | |
| | 3.2 | Wheel Size | front | | mm | Ø 230 x 70 | Ø 250 x 75 | Ø 230 x 70 | Ø 250 x 75 | | | |
| | 3.3 | Wheel Size | rear | | mm | Ø 82 x 110 | | | | | | |
| | 3.4 | Additional Wheels | castor wheel | | mm | Ø 125 x 54 | | | | | | |
| | 3.5 | Wheels | number (x=driven) front/rear | | | 1x + 2/2 | | | | | | |
| | 3.6 | Track Width | front | b10 | mm | 512 | | | | | | |
| | 3.7 | Track Width | rear | b11 | mm | 370 | | | | | | |
| Dimensions | 4.6 | Initial Lift | | h5 | mm | 125 | | | | | | |
| | 4.8 | Operator Stand Height | | h7 | mm | 186 | | | 197 | | | |
| | 4.9 | Tiller Arm Height | in drive position min./max. | h14 | mm | 1056 / 1359 | | 1054/1323 | 1249 | | | |
| | 4.15 | Fork Height | lowered | h13 | mm | 89 | | | | | | |
| | 4.19 | Overall Length *** | initial lift raised | l1 | mm | 2128 / 2588 | | 2622 | | 2703 | | |
| | 4.20 | Headlength *** | initial lift raised | l2 | mm | 978 / 1438 | | 1472 | | 1553 | | |
| | 4.21 | Overall Width | | b1/b2 | mm | 744 | | | | | | |
| | | | standard | thxwxl | mm | 60 x 186 x 1150 | | | | | | |
| | 4.24 | Fork Carriage Width | optional length | l | mm | 650 | | | | | | |
| | 4.25 | Width Across Forks | | b5 | mm | 560 | | | | | | |
| | 4.32 | Ground Clearance | centre of wheelbase | m2 | mm | 29 | | | | | | |
| 4.34 | Working Aisle Width ** | 800x1200 mm initial lift raised | Ast | mm | 2557 / 3002 | | 3037 | 3037 | 3127 | | | |
| 4.35 | Turning Radius ** | initial lift raised | Wa | mm | 1857 / 2302 | | 2337 | 2337 | 2427 | | | |
| Performance | 5.1 | Travel Speed | w. / w.o. load | | km/h | 6.5 / 10.5 | 9.5 / 12.5 | 6.8 / 10.5 | | 9.8 / 12.5 | | |
| | 5.2 | Lift Speed | w. / w.o. load | | m/s | 0.18 / 0.30 | | | | | | |
| | 5.3 | Lowering Speed | w. / w.o. load | | m/s | 0.30 / 0.30 | | | | | | |
| | 5.8 | Max. Gradeability | w. / w.o. load, 5 min. rating | | % | 6 / 15 | | | | | | |
| | 5.10 | Service Brake | | | | electric | | | | | | |
| Motors | 6.1 | Traction Motor | rating at S2 60 min. / H-class | | kW | 3.0 | 4.0 | 3.0 | 4.0 | | | |
| | 6.2 | Lift Motor | rating at S3 10% | | kW | 2.2 | | | | | | |
| | 6.3 | Battery | acc. to DIN 43535 | lxwxh | mm | B | | | | | | |
| | | Max. Battery Box Size | | lxwxh | mm | 284 x 624 x 627 | | | | | | |
| | 6.4 | Battery Voltage | nominal capacity 5h rating | | V/Ah | 24 / 375 | | | | | | |
| | 6.5 | Battery Weight | | | kg | 309 | | | | | | |
| 8.1 | Type Controller | drive | | | AC-transistor | | | | | | | |
| | 8.4 | Sound Level | acc. to EN 12053 | | dB(A) | 59 | | | | | | |

* as double stacker 1000 kg + 1000 kg, as pallet truck 2000 kg and as stacker 1000 kg

** initial lift lowered + 58 mm

*** initial lift lowered – 18 mm

Mast

| | | | | | | | | | | | | | | |
|---------|-----|--------------------|------------------|--------|-----|-------------|-------------|-------------|-------------|-------------------|-------------|-------------|------|------|
| | 1.2 | Model | platform type | | | DT 3040-2.0 | | | | foldable platform | rear entry | side entry | | |
| | | | steering type | | | mechanical | electric | mechanical | electric | | | | | |
| | | | Mast Type | | | TL | TF | TL | TF | TL | | | | |
| Weights | 2.1 | Weight | less battery | | kg | 930 | 960 | 1050 | 960 | 990 | 1080 | 1049 | 1093 | 1078 |
| | 2.2 | Axle Load | w. load | front | kg | 1310 | 1325 | 1370 | 1370 | 1385 | 1430 | 1418 | 1452 | 1442 |
| | | | | rear | kg | 1920 | 1935 | 1980 | 1890 | 1905 | 1950 | 1933 | 1943 | 1938 |
| | 2.3 | Axle Load | w.o. load | front | kg | 960 | 975 | 1020 | 960 | 975 | 1020 | 1088 | 1112 | 1092 |
| rear | | | | kg | 270 | 285 | 330 | 280 | 295 | 340 | 263 | 283 | 288 | |
| Dim. | 4.2 | Mast | collapsed height | h1 | mm | 1270 | 1430 | 1740 | 1270 | 1430 | 1740 | 1270 | 1270 | 1270 |
| | 4.3 | Free Lift | | h2 | mm | - | - | 1355 | - | - | 1355 | - | - | - |
| | 4.4 | Lift Height | | h3+h13 | mm | 1670 | 2100 | 2600 | 1670 | 2100 | 2600 | 1670 | | |
| | 4.5 | Mast | extended height | h4 | mm | 2100 | 2500 | 3025 | 2100 | 2500 | 3025 | 2100 | | |

DT 3040-2.0 foldable platform
mechanical or electronic steering

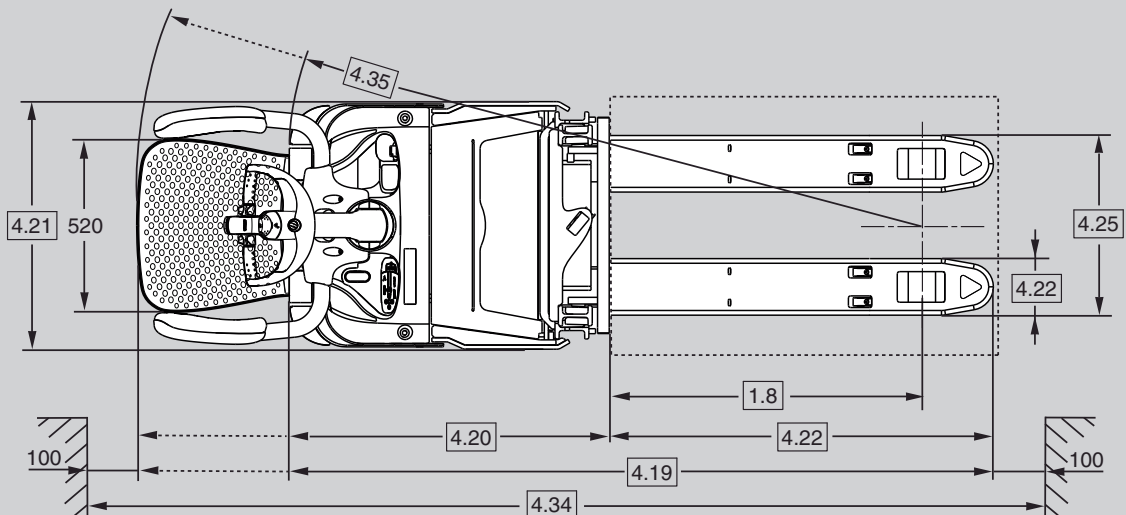
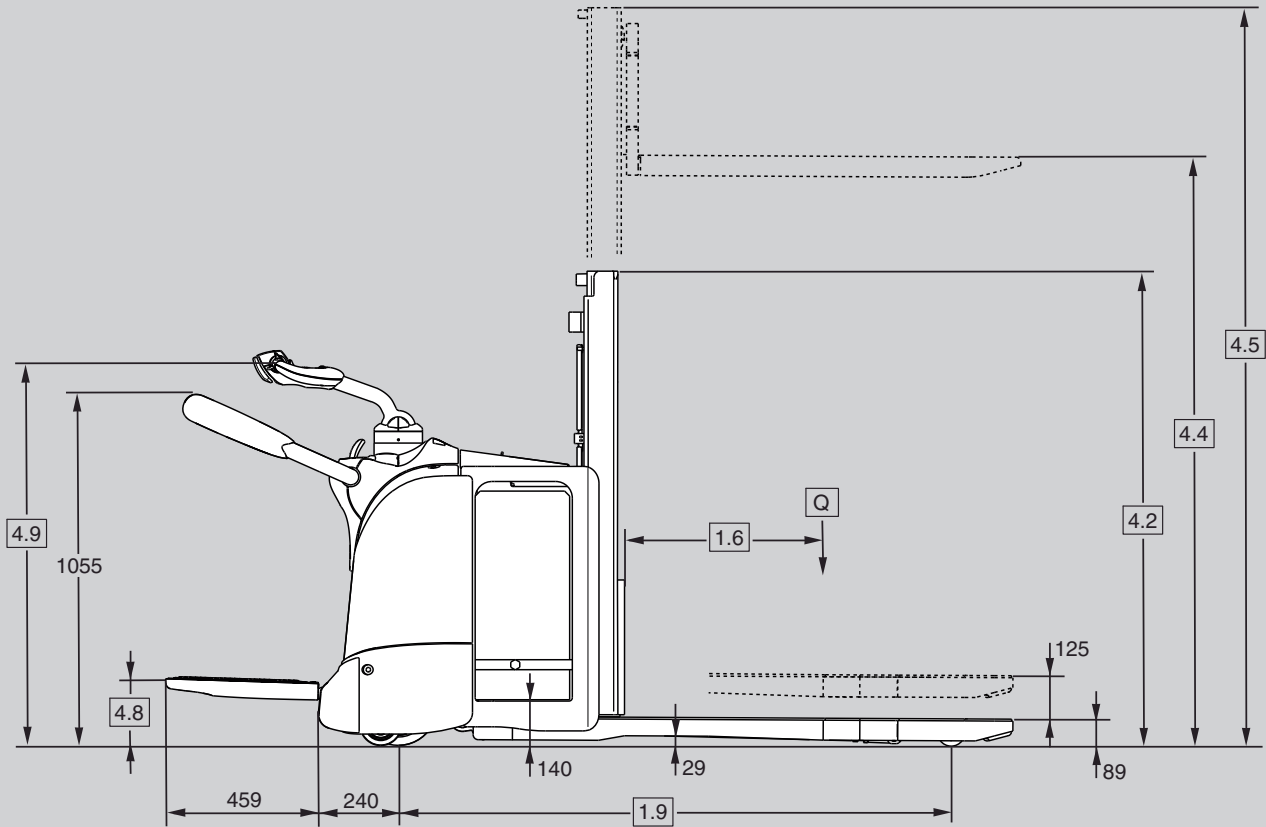

DT 3040-2.0 rear entry fixed platform
mechanical or electronic steering

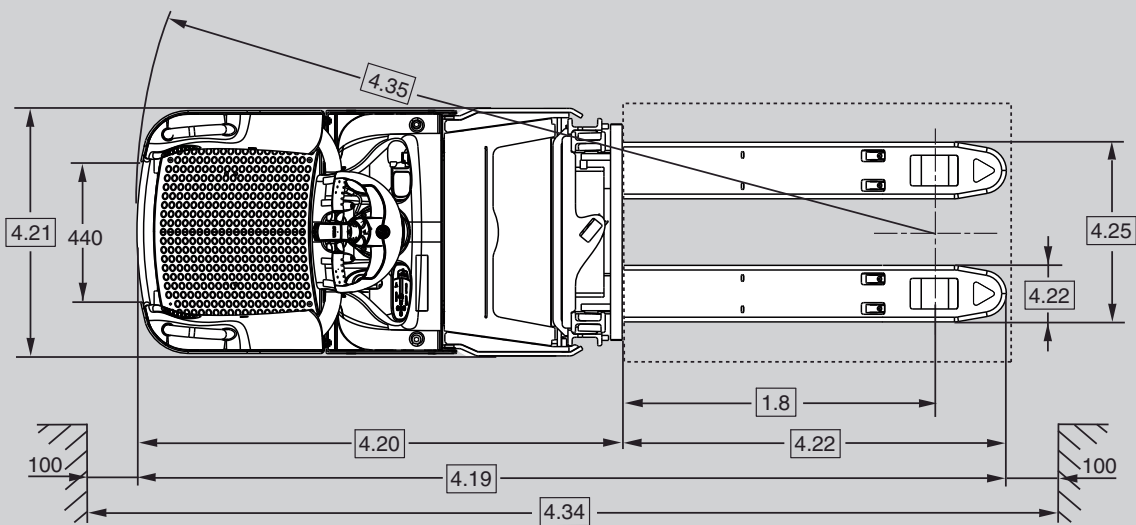
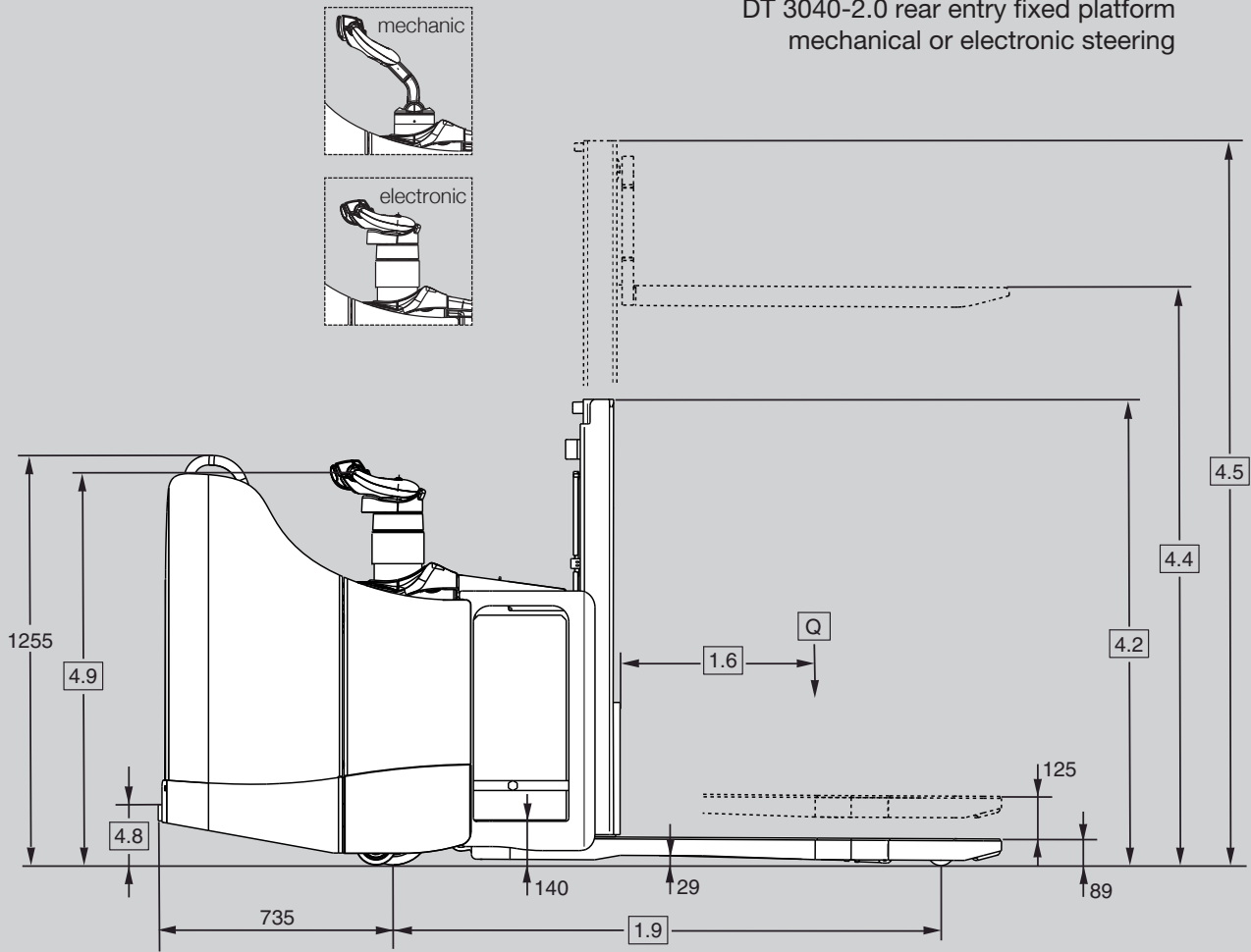

Electric System / Batteries

24-volt electrical system with nominal battery capacities 250 Ah to 375 Ah.

Standard Equipment

1. Maintenance free 3-phase (AC) traction
2. e-GEN® Braking System offers regenerative and frictionless electric braking. Mechanical braking applies only as parking brake
3. The X10® Control Handle places all truck functions at the operator's fingertips.
4. Crown Access 1 2 3® Comprehensive System Control (DT)
 - LCD display
 - Hour meter
 - Keyless start up with PIN code
 - Start up and run time diagnostics
 - Battery discharge indicator and lift interrupt
 - 3 selectable traction performance profiles
 - Onboard diagnostics with real time troubleshooting capabilities
5. FlexRide™ reduces vibrations and shocks to a minimum by combining (foldable platform only)
 - Soft floor mat with integrated presence sensor
 - Advanced platform suspension
 - Fully suspended drive unit

6. CAN-Bus technology (DT)
7. Heavy-duty side restraints with soft side pads and quick-exit feature (foldable platform only)
8. Electric power disconnect switch (DT)
9. Vulkollan drive tyre, castor wheels and load wheels
10. Single load wheels
11. Ramp hold
12. Battery connector - DIN 160A (DT) - SBE 160 red (DS)
13. Easily removable steel covers
14. Hinged steel top battery cover for easy battery access
15. Rabbit/turtle switch incorporates two levels of programmable travel performance
16. Proportional lifting/lowering
17. Heavy-duty castor wheels (DT)
18. Fully suspended drive unit (DT)
19. Soft floor mat with integrated presence sensor (platform trucks only)
20. Pallet stop at initial lift for quick double stacking
21. Battery compartment rollers for horizontal battery removal (DT)
22. Plexiglas mast guard
23. Battery discharge indicator with lift lockout and integrated hour meter and fault code readout (DS)
24. Fork tip indicators

Optional Equipment

1. Without foldable platform (DT)
2. Rear entry fixed platform (DT)
3. Side entry fixed platform (electronic steering only) (DT)
4. Weight-adjustable FlexRide (rear entry fixed platform only)
5. Intelligent Electronic Steering System (platform trucks only)
 - Selectable performance profiles for speed reduction on curves
 - Tactile feedback feature analyses operational conditions and adjusts steering force for optimised control
 - Active Traction System adjusts drive tyre pressure as load weight changes
6. Outrigger lift/lower switches on left and right side of X10 Control Handle
7. Battery connector - SBE 160 red (DT) - DIN 160A (DS)
8. Rubber (DT) or Supertrac (DS and DT) drive tyre
9. Tandem load wheels
10. Heavy-duty dual castor wheels (DT)
11. Freezer conditioning (DT)
12. InfoLink® ready (DT)
13. Key switch or key pad
14. Load backrest

15. Work Assist accessory tube (DT)
16. Work Assist Accessories (DT)
 - Storage pockets
 - Scan gun holder
 - Small and medium clipboards
 - Mounting brackets for WMS terminals
17. Special paint
18. Metal mast grill
19. Lithium-Ion Battery Ready
20. Fork lift switches on both sides of the mast (DS). Max. lift height 850 mm + 120 mm initial lift. Not in combination with load backrest.
21. 30 A sealed on-board charger (DS)
22. 12 V clean power supply (DT)
23. 24 V power supply (DT)
24. Welded fork marks

Electrical

A heavy-duty 24 volt fused electrical system provides optimum travel and lift speed.

Virtually maintenance-free AC traction motor provides strong acceleration and control at any speed.

The DT 3000 Series is equipped with sensors which monitor functional parameters including steering, load weight, height, drive mode and speed, and adjusts operational settings automatically to suit conditions.

Power Unit

The DT 3000 Series is designed to take the abuse of dock work, the rugged power unit features a reinforced 10 mm thick skirt to protect drive unit and castor components. A 12 mm skirt protects the battery and lift linkage. The contoured skirt provides greater ground clearance for working on ramps. Removable steel covers all around ensure internal components are protected against impacts yet easily accessible for service.

Comfort

The DT 3000 Series incorporates numerous design features to improve operator comfort and productivity.

The folding FlexRide™ platform reduces shock transfer to the operator by more than 80 percent. Dock boards can be crossed without reducing speed. The lifetime platform suspension never requires adjustment and features solid state induction switches to avoid reliability issues caused by contaminants.

Heavy-duty side restraints feature 50 mm heavy-wall steel tubing and rugged C-clamp mounting system. Soft polyurethane side pads are positioned for excellent support and comfort.

The quick-exit feature (patent pending) allows the restraints to swing up for faster access to the load.

Fixed platform models feature a patented Entry Bar Switch which stops the truck if the operator's foot is outside the truck perimeter. Low step height and wide, rounded access make it easy to step on and off the truck. The rear-entry platform incorporates large side cushions for soft support in side-stance position. A contoured lean pad on the side entry platform provides a soft contact surface to lean against.

Patented weight-adjustable FlexRide – optional on the rear entry model - provides the ultimate rider comfort by tuning the suspension for the operator's body weight.

Available electronic steering improves manoeuvrability and responsiveness, even with heavy loads. An intelligent tactile feedback feature analyses operational conditions and adjusts steering force for greater driver confidence. Combined with Active Traction and speed control on curves, electronic steering safely delivers top driving performance.

Operator Controls

The X10 Control Handle, designed for simultaneous operation of all functions with one hand, improves side-stance operation for maximum visibility in both driving directions. An ergonomic forward/reverse thumb wheel allows for precise manoeuvring. The hand grips are urethane covered for insulation from cold and vibration with integrated horn buttons for easy activation.

A rabbit/turtle switch incorporates two levels of programmable travel performance so operators can select the setting that matches their experience level or application requirements.

Proportional lift and lowering allows easy and precise positioning of loads. The fast responsiveness and speeds of the lifting and lowering functions are designed to meet the high demanding double stacker applications and all this together at a low noise level.

Access 1 2 3® Comprehensive System Control (DT)

Crown's Access 1 2 3 technology provides optimum performance and control by offering a communications interface for the operator and service engineer, intelligent coordination of lift truck systems and simplified service with advanced diagnostics.

The display includes a full featured on-board service tool so service engineers can actively view inputs and outputs during truck operation. No laptop or service terminal is required. Event code history, including the last 16 events, is accessible through the display.

The display provides a convenient interface for operators, keeping them informed (hour meter, BDI, operator messages, service codes) of any changes impacting truck performance and allowing them to choose from three performance profiles when enabled.

Performance tuning can be accessed at the display to customise truck performance for specific applications or operator requirements. In addition, up to 25 PIN codes can be assigned to individual operators and matched to one of the pre-programmed performance profiles if desired.

Power Unit Suspension (DT)

The drive unit suspension utilises hard-plated chrome rods and sealed slide bushings for long life without adjustment. The suspension provides 60 mm of travel with constant drive tyre pressure for excellent performance on ramps. The system reduces shocks to the chassis, mounted components and the operator.

Active Traction, standard on trucks with electronic steering, uses hydraulic pressure to increase traction. Reduced slipping and improved braking are especially helpful on steep or wet ramps.

e-GEN® Braking System

The power of the high-torque AC traction motor is used to stop the truck and keep it static until a travel input is requested, even when operating on a gradient. This system eliminates adjustments and wear points for a lifetime of maintenance free use.

An automatic parking brake activates if the truck is stopped and the operator leaves the platform or power is disconnected.

Safety Regulations

Conforms to European safety standards.

Dimensions and performance data given may vary due to manufacturing tolerances. Performance is based on an average size vehicle and is affected by weight, condition of truck, how it is equipped and the conditions of the operating area. Crown products and specifications are subject to change without notice.