



# RM 6000 RMD 6000 SERIES

## Specifications

Narrow-Aisle Reach Truck  
S Class





**RM 6000 Series  
S Class**

Narrow-Aisle Reach Truck

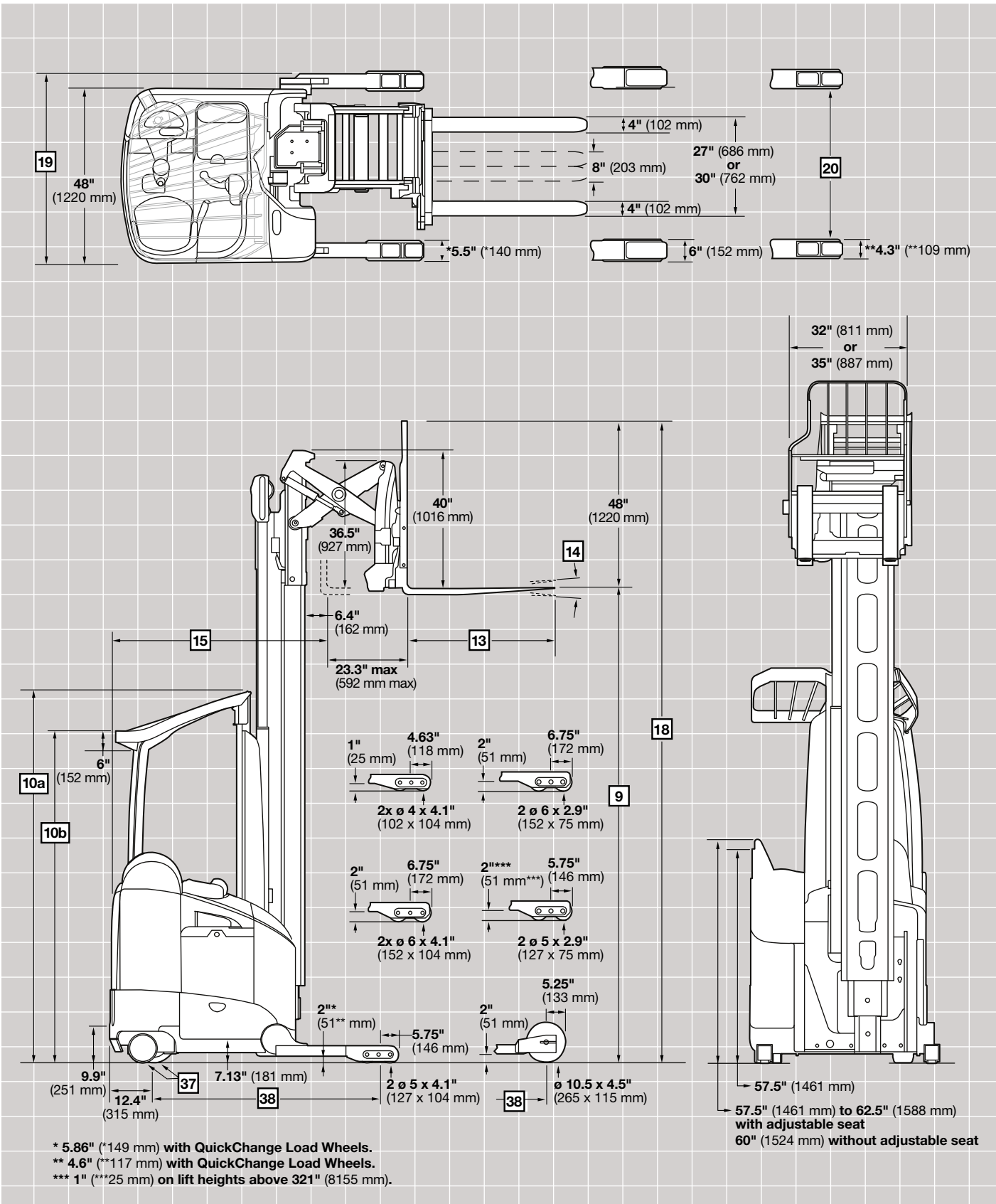

**RM 6000 Series  
S Class**

Specifications

General Information	1	Manufacturer	Crown Equipment Corporation			
	2	Model	RM 6095S			
	3	Load Capacity*	Max	lb kg	4500	2000
	4	Load Center	Fork Face to Load CG	in mm	24	600
	5	Power	36 Volts			
	6	Operator Type	Reach Sit / Stand			
	7	Tire Type	Load/Caster/Drive Poly / Poly / Poly			
	8	Wheels (x = driven)	Load/Power Unit 4 / 2 (1x)			
Dimensions	9	Mast Type	High Visibility MM			
	9	Lift Height	in mm	See Mast Chart Below		
	10	Guard Height	in mm	See Mast Chart Below		
	13	Forks	Standard L x W x T	in mm	36 x 4 x 1.75	914 x 102 x 45
			Optional Lengths	in mm	30, 39, 42, 45, 48	762, 990, 1065, 1145, 1220
	14	Carriage	Tilt F°/B°	degree	3/4	
	15	Headlength**	Compartment "E"	in mm	62.40	1585
			Compartment "F"	in mm	65.90	1673
	17	Overall Collapsed Height	in mm See Mast Chart Below			
	18	Overall Extended Height	in mm See Mast Chart Below			
Performance	19	Overall Truck Width	in mm See Truck Width Chart, page 6			
	20	Inside Straddle Width***	In 1" (25 mm) increments	in mm	34 - 50	865-1270
	24	Speed Travel	Power Unit First (E/L)	mph km/h	8.3 / 7.5	13.4 / 12.1
			Forks First (E/L)	mph km/h	6.9 / 6.2	11.1 / 10.0
	25	Speed Lift - AC †	Empty	fpm mm/s	160	813
			1000 lb (454 kg)	fpm mm/s	139	706
			2000 lb (907 kg)	fpm mm/s	121	615
			3000 lb (1361 kg)	fpm mm/s	105	533
			3500 lb (1586 kg)	fpm mm/s	98	498
			4000 lb (1815 kg)	fpm mm/s	96	488
		4500 lb (2000 kg)	fpm mm/s	95	483	
26	Speed Lower	Empty/Loaded	fpm mm/s	110 / 110	559 / 559	
26a	Speed Xpress™ Lower	Empty/Loaded	fpm mm/s	110 - 240 / 110 - 240 ††	559-1219 / 559-1219 ††	
37	Tires	Size - Drive/Caster	in mm	13 x 5.5 / 8.5 x 2.7 x (2)	330 x 140 / 216 x 69 (2)	
Chassis	38	Wheelbase (Standard Wheel)	Compartment "E"	in mm	64.88	1648
			Compartment "F"	in mm	68.38	1737
	39	Suspension	Drive	Articulated		
			Caster	Articulated, Swivel		
42	Brakes	Drive	Elec Release / Mech Applied			
		Caster	Electronically Applied			
		Parking	Elec Release / Mech Applied			

\* Contact factory. Capacity may be subject to derating at height.  
 \*\* Sideshift included.  
 \*\*\* Inside straddle is decreased .35" (9 mm) with Quick Change Load Wheels.  
 † Maximum lift speeds with the maximum available battery compartment.  
 †† Average speed is 205 fpm (1041 mm/s).

**RM 6000 Series  
S Class**

Specifications

Mast Chart	TT - RM 6095S																
	9	Lift Height	in mm	192	4875	210	5335	240	6095	270	6860	300	7620	321	8155	341	8660
		Free Lift*	in mm	27	685	39	990	59	1495	71	1800	83	2105	92	2335	101	2565
	10a	Guard Height- Top Front	in mm	89	2261	95	2413	107	2718	107	2718	107	2718	107	2718	107	2718
	10b	Guard Height- Top Back	in mm	89	2261	95	2413	95	2413	95	2413	95	2413	95	2413	95	2413
	17	Overall Collapsed Height	in mm	89	2260	95	2415	107	2720	119	3025	131	3325	140	3555	149	3785
	18	Overall Extended Height*	in mm	240	6100	258	6555	288	7315	318	8080	348	8840	369	9375	389	9880
		Minimum Straddle OD	in mm	42	1067	42	1067	42	1067	42	1067	42	1067	42	1067	42	1067
Weight	RM 6095S																
	Truck Weight w/o Battery																
	Battery Compartment		"E"	lb kg	6894	3127	7013	3181	7205	3268	7513	3408	7773	3526	8058	3655	8201
		"F"	lb kg	7000	3175	7119	3229	7311	3316	7619	3456	7879	3574	8166	3704	8307	3768
Mast Chart	TT - RM 6095S																
	9	Lift Height	in mm	366	9295	400	10160	421	10690	442	11225	475	12065	505	12825		
		Free Lift*	in mm	112	2845	124	3150	130	3305	142	3605	154	3910	166	4215		
	10a	Guard Height- Top Front	in mm	107	2718	107	2718	107	2718	107	2718	107	2718	107	2718		
	10b	Guard Height- Top Back	in mm	95	2413	95	2413	95	2413	95	2413	95	2413	95	2413		
	17	Overall Collapsed Height	in mm	160	4065	172	4370	178	4520	190	4825	202	5130	214	5435		
	18	Overall Extended Height*	in mm	414	10515	448	11380	469	11915	490	12450	523	13285	553	14050		
		Minimum Straddle OD	in mm	45	1143	48	1219	50	1270	50	1270	50	1270	50	1270		
Weight	RM 6095S																
	Truck Weight w/o Battery																
	Battery Compartment		"E"	lb kg	8450	3833	8662	3929	8783	3984	na	na	na	na	na	na	
		"F"	lb kg	8556	3881	8770	3978	8889	4032	9129	4141	9425	4275	9610	4359		

\* With load backrest 48" (1220 mm).  
 Note: Above 321" (8155 mm), 6" (152 mm) high load wheel standard.



**RMD 6000 Series S Class**

Narrow-Aisle Reach Truck

**RMD 6000 Series S Class**

Specifications

**RMD 6000 Series S Class**

Specifications

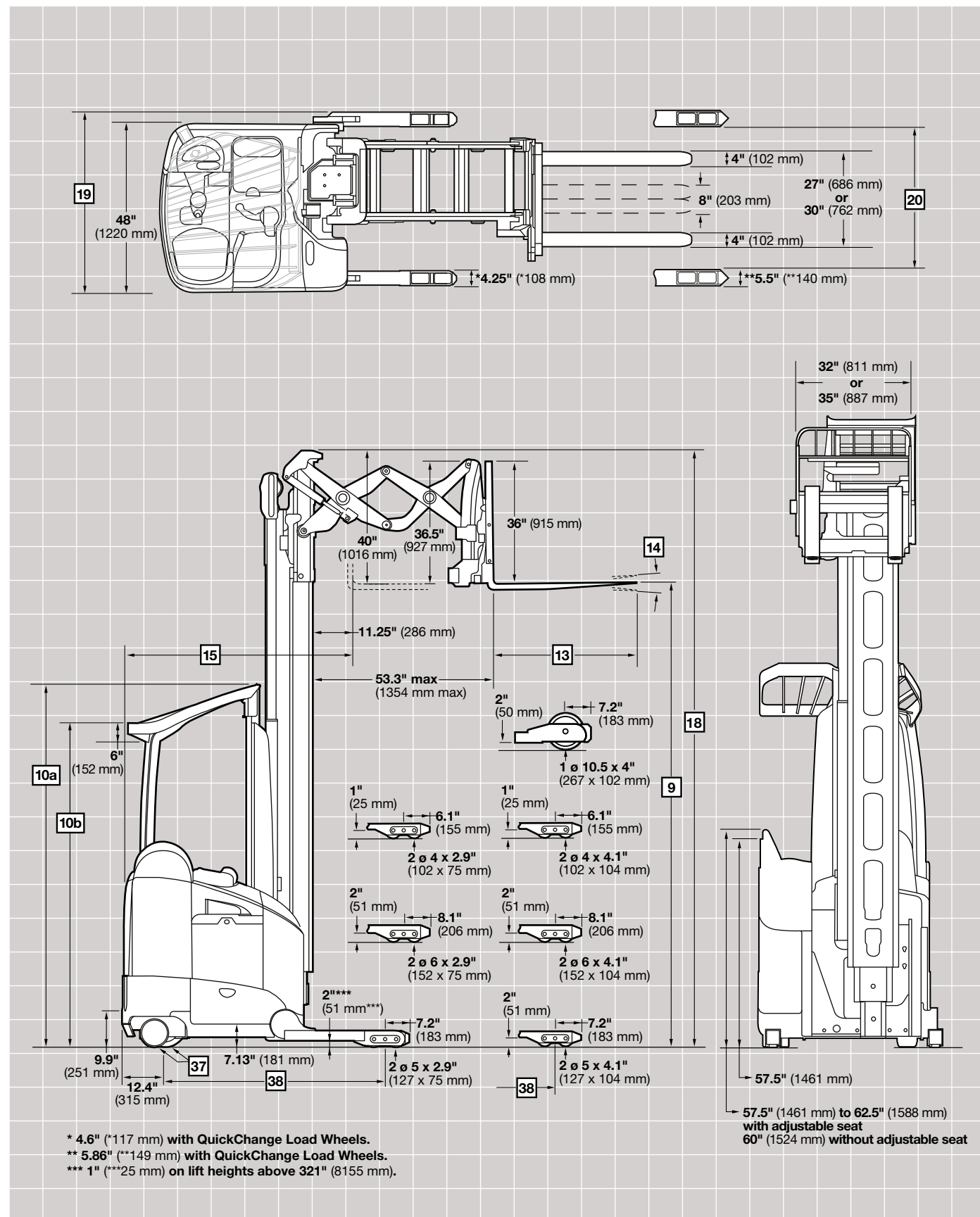

<b>General Information</b>	1	<b>Manufacturer</b>		<b>Crown Equipment Corporation</b>		
	2	<b>Model</b>		<b>RMD 6095S</b>		
	3	<b>Load Capacity*</b>	Max	lb kg	3200	1450
	4	<b>Load Center</b>	Fork Face to Load CG	in mm	24	600
	5	<b>Power</b>			36 Volts	
	6	<b>Operator Type</b>	Reach		Sit / Stand	
	7	<b>Tire Type</b>	Load/Caster/Drive		Poly / Poly / Poly	
	8	<b>Wheels (x = driven)</b>	Load/Power Unit		4 / 2 (1x)	
<b>Dimensions</b>		<b>Mast Type</b>		MM		
	9	<b>Lift Height</b>		in mm	See Mast Chart Below	
	10	<b>Guard Height</b>		in mm	See Mast Chart Below	
	13	<b>Forks</b>	Standard L x W x T	in mm	36 x 4 x 1.5	914 x 102 x 45
			Optional Lengths	in mm	30, 39, 42, 45, 48	762, 990, 1065, 1145, 1220
	14	<b>Carriage</b>	Tilt F°/B°	degree	3/4	
	15	<b>Headlength**</b>	Compartment "E"	in mm	67.30	1709
			Compartment "F"	in mm	70.80	1798
	17	<b>Overall Collapsed Height</b>		in mm	See Mast Chart Below	
	18	<b>Overall Extended Height</b>		in mm	See Mast Chart Below	
<b>Performance</b>	19	<b>Overall Truck Width</b>		in mm	See Truck Width Chart, page 6	
	20	<b>Inside Straddle Width***</b>	In 1" (25 mm) increments	in mm	34 - 50	865 - 1270
	24	<b>Speed Travel</b>	Power Unit First (E/L)	mph km/h	8.3 / 7.5	13.4 / 12.1
			Forks First (E/L)	mph km/h	6.9 / 6.2	11.1 / 10.0
	25	<b>Speed Lift - AC †</b>	Empty	fpm mm/s	160	813
			1000 lb (454 kg)	fpm mm/s	139	706
			2000 lb (907 kg)	fpm mm/s	121	615
			3000 lb (1361 kg)	fpm mm/s	105	533
	26	<b>Speed Lower</b>	Empty/Loaded	fpm mm/s	110 / 110	559 / 559
	26a	<b>Speed Xpress™ Lower</b>	Empty/Loaded	fpm mm/s	110 - 240 / 110 - 240 ††	559-1219 / 559-1219 ††
<b>Chassis</b>	37	<b>Tires</b>	Size - Drive/Caster	in mm	13 x 5.5 / 8.5 x 2.7 x (2)	330 x 140 / 216 x 69x (2)
	38	<b>Wheelbase (Standard Wheel)</b>	Compartment "E"	in mm	64.88	1648
			Compartment "F"	in mm	68.38	1737
	39	<b>Suspension</b>	Drive		Articulated	
		Caster		Articulated, Swivel		
42	<b>Brakes</b>	Drive		Elec Release / Mech Applied		
		Caster		Electronically Applied		
		Parking		Elec Release / Mech Applied		

\* Contact factory. Capacity may be subject to derating at height.  
 \*\* Sideshift included.  
 \*\*\* Inside straddle is decreased .35" (9 mm) with Quick Change Load Wheels.  
 † Maximum lift speeds with the maximum available battery compartment.  
 †† Average speed is 205 fpm (1041 mm/s).

<b>Mast Chart</b>		<b>TT - RMD 6095S</b>															
<b>Mast</b>	9	Lift Height	in mm	192	4875	210	5335	240	6095	270	6860	300	7620	321	8155	341	8660
		Free Lift*	in mm	27	685	39	990	63	1600	75	1905	87	2210	96	2438	105	2667
	10a	Guard Height- Top Front	in mm	89	2261	95	2413	107	2718	107	2718	107	2718	107	2718	107	2718
	10b	Guard Height- Top Back	in mm	89	2261	95	2413	95	2413	95	2413	95	2413	95	2413	95	2413
	17	Overall Collapsed Height	in mm	89	2260	95	2415	107	2720	119	3025	131	3325	140	3555	149	3785
	18	Overall Extended Height*	in mm	234	5945	250	6350	288	7115	310	7875	340	8640	361	9170	381	9680
	Minimum Straddle OD	in mm	42	1067	42	1067	42	1067	42	1067	42	1067	42	1067	42	1067	
<b>Weight</b>		Truck Weight w/o Battery		<b>RMD 6095S</b>													
		Battery Compartment	"E" lb kg	7079	3211	7198	3265	7390	3352	7701	3493	7961	3611	8245	3740	8386	3804
		"F" lb kg	7185	3259	7304	3313	7498	3401	7807	3541	8067	3659	8351	3788	8492	3852	

<b>Mast Chart</b>		<b>TT - RMD 6095S</b>															
<b>Mast</b>	9	Lift Height	in mm	366	9295	400	10160	421	10695	442	11225	475	12065	505	12825		
		Free Lift*	in mm	116	2946	128	3251	134	3403	146	3708	158	4013	170	4318		
	10a	Guard Height- Top Front	in mm	107	2718	107	2718	107	2718	107	2718	107	2718	107	2718		
	10b	Guard Height- Top Back	in mm	95	2413	95	2413	95	2413	95	2413	95	2413	95	2413		
	17	Overall Collapsed Height	in mm	160	4065	172	4370	178	4520	190	4825	202	5130	214	5435		
	18	Overall Extended Height*	in mm	406	10315	440	11180	461	11710	482	12245	515	13085	545	13845		
	Minimum Straddle OD	in mm	45	1143	48	1219	50	1270	50	1270	50	1270	50	1270			
<b>Weight</b>		Truck Weight w/o Battery		<b>RMD 6095S</b>													
		Battery Compartment	"E" lb kg	8635	3917	8849	4014	8968	4068	na	na	na	na	na	na		
		"F" lb kg	8741	3965	8955	4062	9074	4116	9315	4225	9610	4359	9795	4443			

\* To reach carriage with load backrest 36" (915 mm).  
 Note: Above 321" (8155 mm), 6" (152 mm) high load wheel standard.

**RM 6000 Series  
RMD 6000 Series  
S Class**

Specifications

<b>Battery</b>	<b>Battery Removal</b>	Caster Side			
	45 <b>Type</b>	Lead Acid			
	46	<b>Min Weight/Max Amp-hrs</b>			
		<b>Compartment "E"</b>			
		"C" Battery - Up to 321" (8155 mm)	lb/Ah kg/Ah	2000 / 930	907 / 930
		"D" Battery - Up to 341" (8660 mm)	lb/Ah kg/Ah	2280 / 1085	1034 / 1085
		"E" Battery - ≤ 400" (10160 mm)	lb/Ah kg/Ah	2600 / 1240	1179 / 1240
		"E" Battery - 401" - 421" (10185 - 10695 mm)	lb/Ah kg/Ah	2800 / 1240	1270 / 1240
		<b>Compartment "F"</b>			
		"E" Battery - ≤ 400" (10160 mm)	lb/Ah kg/Ah	2600 / 1240	1179 / 1240
		"E" Battery - 401" - 505" (10185 - 12825 mm)	lb/Ah kg/Ah	2800 / 1240	1270 / 1240
		"F" Battery	lb/Ah kg/Ah	3100 / 1395	1407 / 1395
		<b>Max Battery Size</b>			
		<b>Compartment "E"</b>			
		<b>L x W x H</b>			
	"C" Battery	in mm	38.38 x 16.25 x 31	975 x 413 x 787	
	"D" Battery	in mm	38.69 x 18.00 x 31	983 x 457 x 787	
	"E" Battery	in mm	38.69 x 20.75 x 31	983 x 527 x 787	
	<b>Compartment "F"</b>				
	"E" Battery	in mm	38.69 x 20.75 x 31	983 x 527 x 787	
	"F" Battery	in mm	38.69 x 22.75 x 31	983 x 578 x 787	
	<b>Connector Location / Length (J)</b>	A / 9"		A / 230 mm	
	<b>Standard Connector</b>	SB350 Gray			

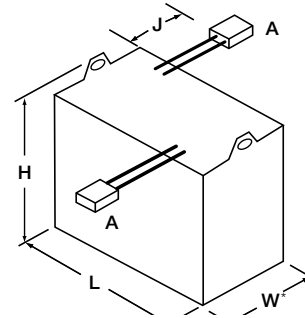

\* Width is measured on the side of the battery with lifting hooks

<b>Truck Width Chart</b>																	
Overall truck width is either the power unit width (48") (1220 mm) or outrigger OD, whichever is greater. Due to the offset mast and outriggers on the RM, there are some cases when the overall truck width differs from this.																	
OD	Load Wheel Width		Overall Truck Width		OD	Load Wheel Width		Overall Truck Width		OD	Load Wheel Width		Overall Truck Width				
45	1143	2.9	75	49.25	1251	45	1143	4.0 & 4.1	102 & 104	49.0	1245	49	1245	4.5	115	51.0	1295
46	1168	2.9	75	49.75	1264	46	1168	4.0 & 4.1	102 & 104	49.5	1257	50	1270	4.5	115	51.5	1308
47	1194	2.9	75	50.25	1277	47	1194	4.0 & 4.1	102 & 104	50.0	1270	51	1295	4.5	115	52.0	1321
48	1220	2.9	75	50.75	1289	48	1220	4.0 & 4.1	102 & 104	50.5	1283	52	1321	4.5	115	52.5	1334
49	1245	2.9	75	51.25	1302	49	1245	4.0 & 4.1	102 & 104	51.0	1295						
50	1270	2.9	75	51.75	1315	50	1270	4.0 & 4.1	102 & 104	51.5	1308						
51	1295	2.9	75	52.25	1327	51	1295	4.0 & 4.1	102 & 104	52.0	1321						
52	1321	2.9	75	52.75	1340	52	1321	4.0 & 4.1	102 & 104	52.5	1334						

**Capacity**

Model RM 6095S: 4500 lb (2000 kg) at 24" (600 mm) load center, 36 volt

Model RMD 6095S: 3200 lb (1450 kg) at 24" (600 mm) load center, 36 volt

**Batteries**

Battery removal from right side of truck. Standard battery compartment rollers for extraction with mechanized equipment.

**Standard Equipment**

1. MonoLift® mast
2. Crown's Access 1 2 3® Comprehensive System Control
3. 36 volt system
4. AC Traction System
5. AC Hydraulics with electronic power steering
6. Regenerative Lowering
7. OnTrac® Anti-Slip Traction Control
8. Operator Compartment
  - Variable side stance
  - Flexible five-point positioning
  - Adjustable suspended seat, perch, backrest, and Multi-Task Control armrest
  - Adjustable steer tiller
  - Back support with integral hip support
  - Arm/elbow support padding
  - Padded compartment interior walls
  - Operator console with work surface and storage
  - Entry Bar® safety switch
  - Suspended floor
  - 383 in<sup>2</sup> (2470 cm<sup>2</sup>) floor area
  - 178 in<sup>2</sup> (1150 cm<sup>2</sup>) upper footrest area
  - Premium urethane floorboard cushion
  - Work Assist® Mirror
9. Multi-task control handle
10. Crown display
  - Event code display with five (5) key navigation
  - Hour meters / travel distance / stop watch
  - PIN Code access capable
  - Access 1 2 3 diagnostics
  - P1, P2, P3 performance tuning
  - Battery discharge indicator, steer wheel direction indicator, OnTrac® Traction Control indicator

11. High visibility power unit
  12. Angled overhead guard
  13. Polycarbonate mast guard
  14. Integrated sideshift RM-2" (51 mm) or 4" (102 mm), RMD-2" (51 mm)
  15. Load backrest- RM-48" (1220 mm), RMD-36" (915 mm)
  16. Tilting fork carriage
  17. Tandem articulating load wheels
  18. Lift slow down 12" (305 mm) from maximum lift height
  19. Lift Limit without override
  20. Chain slack detection
  21. Crown-manufactured drive and lift motors
  22. Offset articulated drive axle with 190° steer arc
  23. Horn
  24. Emergency power disconnect
  25. 350 amp battery connector
  26. Large diameter battery rollers
  27. Color-coded wiring
  28. Third post
  29. Forward steering
  30. InfoPoint® System with Quick Reference Guide
  31. Static Strap
  32. WorkAssist® Accessory Tube
- Optional Equipment**
1. Xpress™ Lower
  2. Rack Height Select and Tilt Position Assist
  3. Capacity monitor
  4. Camera and color monitor (Must be Collapsed Height ≥ 26" (660 mm) above Overhead Guard)
  5. Lift limit with override
  6. Zone Select Key switch
  7. Bolt-on outrigger tips
  8. Quick Change bolt-on outrigger tips
  9. Mesh screen mast guard
  10. Battery retainer with interlock
  11. V-Force® Lithium-Ion Ready
  12. Fuel Cell Ready
  13. Thin Plate Pure Lead (TPPL) Ready
  14. Load backrest RM- 36" (915 mm) and 42" (1067 mm) RMD- 42" (1067 mm) and 48" (1220 mm)
  15. Overhead guard mesh
  16. Flat overhead guard
  17. Polished and tapered forks

**RM 6000 Series  
RMD 6000 Series  
S Class**

Technical Information

18. Fork lengths
19. Heavy-duty skirt
20. Floor Spotlight - Blue
21. Work light
22. LED flashing light
23. Console area light
24. Travel alarm
25. Keyless on/off switch
26. Corrosion/freezer conditioning (freezer conditioning includes a 5/8" (16 mm) thick power unit skirt with extended coverage of the drive and caster tires)
27. ThermoAssist™ freezer comfort package
28. UL EE Rating
29. Load wheel sizes and compounds
30. Drive tire compounds
31. Reverse Steering
  - Short steer tiller
  - Maintenance platform
  - Remote raise/lower
32. Work Assist® Accessories:
  - Accessory RF mounting plate
  - Accessory RF mounting bracket
  - Accessory clamp
  - Accessory clip pad
  - Accessory hook
  - Accessory clip pad and hook
  - Accessory pocket
  - Organizer kits
  - Console light
  - Fan
33. InfoLink® Ready

**Operator Compartment**

Soft, rounded surfaces make compartment interior more comfortable. Streamlined exterior smooths entry/exit for the operator. A low floor height, (9.9") (251 mm), first greets the operator. A 383 in<sup>2</sup> (2470 cm<sup>2</sup>) floor and patented suspended floorboard provide comfortable footing.

All S Class reach trucks include an upper footrest area, (178 in<sup>2</sup>) (1150 cm<sup>2</sup>) with smart foot interlocks and brake control. Using these large, exclusive footrests can improve operator comfort. From the standing position, the ability to lift either leg to a footrest can reduce fatigue which increases productivity.

The brake pedal design allows variable side-stance positions for the operator. The operator can change positions to increase comfort and productivity.

The S Class model offers a superior level of flexibility for the operator with an adjustable suspended seat, perch, backrest, armrest, control handle and steer tiller. The combination of these features lets the operator move from a standing, leaning or seated driver position. The stress of standing can be relieved by sitting and the stresses of sitting can be relieved by standing. By changing postures and using different sets of muscles, significant ergonomic, physiological and orthopedic benefits may result.

Five-point positioning provides control and stability, starting with the right hand on the multi-task controller and the left hand on the steer tiller. Left foot on the brake pedal and the right foot on the presence sensor. The operator's back is naturally fitted against the wrap-around support cushion.

The Entry Bar™ safety switch with sensors to automatically slow truck travel, encourages safe foot positioning inside the truck.

The multi-task control enables the operator to maneuver the truck while blending lift and accessory functions for improved productivity. Control handle activation forces are reduced. The soft grip steer tiller with hydrostatic steering or optional electronic power steering reduces operator fatigue.

Operator visibility is improved with:

- Low profile power unit
- MonoLift® mast
- Angled overhead guard
- Variable side stance

Superior thermal management is the result of several design features: reduced heat generating components, positioning of heat generating components away from the compartment, padding to insulate the compartment from heat, and improved air paths through the truck.

Clipboard surface and console storage pockets are standard.

# RM 6000 Series RMD 6000 Series S Class

## Technical Information

### **Crown's Access 1 2 3® Comprehensive System Control**

provides optimum performance and control by offering a communication interface for operators and technicians, intelligent coordination of lift truck systems and simplified service with advanced diagnostics.

The Crown display is used for easy trouble shooting, accessing service history and setting performance features. A distribution panel is conveniently located with all test points, control fuses and central wiring for easy troubleshooting.

Three modes of performance can be selected to accommodate operator experience or application requirements.

### **OnTrac® Anti-Slip Traction Control**

Crown's Access 1 2 3 technology monitors truck dynamics, optimizes traction, reduces spinning during acceleration, prevents lock-up during braking, and greatly extends tire life.

### **Travel**

Crown's AC traction system is a closed loop traction control system that maintains top speed throughout the battery charge. Engineered and manufactured by Crown, the AC motor, controller and drive unit are designed specifically for lift truck applications.

On an inclined surface or when interfacing with push-back racking, the "truck hold" feature electronically brakes the truck when the handle is in neutral. The operator does not have to release the brake pedal, improving comfort and control in these applications. Selected travel speed remains constant regardless of surfaces, load weight or grades. Less throttling of control handle means better truck control and less fatigue to the operator.

### **Steering**

Drive tire rotates 190° for maximum maneuverability.

The electronic power steering uses an AC steer motor and steering control module integrated with the Access 1 2 3 System for fast, reliable steering response. The smooth, quiet steering requires minimal operator effort at the steer tiller.

### **Braking**

A disc brake on the motor armature shaft combined with motor regenerative braking provides sure braking with fewer parts and maintenance requirements. The offset, articulated drive-unit design improves drive tire brake force.

Regenerative motor braking helps save energy, and decreases motor temperature.

### **Suspension**

The offset, articulated drive-unit design provides positive floor contact.

### **Load Handling**

The optional Load Handling Assist package provides rack height select and tilt position assist features.

The Rack Height Select feature allows the truck to be programmed to stop at preselected heights. With one-touch of the multi-task trigger while lifting or lowering, the mast will stop at the next programmed height.

Another useful option is the Tilt Position Assist. This allows the fork tilt to stop at a preprogrammed position for maximum fork clearance when entering pallets.

Also optional, the Capacity Monitor shows the approximate weight on the forks and the fork height. It will alert the operator when the truck capacity is exceeded for the fork height. It will also show how high or to which lift zone you can raise the load.

### **Mast**

The MonoLift® mast design with angled overhead guard improves visibility for high or low stacking. Crown's patented staging cushions coupled with lowering dampers and speed reductions at maximum lift improve overall load handling control.

Elevated load sway and side bowing are minimized through the use of a closed cross-section mast construction. Rolled "I-beams" continuously welded to a formed plate create a full length, deep cross-section mast capable of resisting front and side loading equally well. Lift cylinders, hoses, cable and chain within the mast are protected from the operating environment, but are readily accessible for service. Built-in sensors detect chain slack and shut down lower functions.

### **Xpress™ Lower**

The optional Xpress Lower feature dramatically increases lower speeds allowing you to reduce cycle times and increase productivity. Trucks equipped with Xpress Lower take advantage of three automatically controlled lower speed zones to ensure optimum performance and safety.

### **Reach Mechanism**

The cast reach carriage is sculpted to allow for excellent visibility to the load and forks. A soft start/stop of the reach mechanism is critical to operator confidence and load stability. A sensor recognizes when the reach and retract functions are starting or stopping and adjusts the speed accordingly.

### **Carriage**

A hook-type carriage conforming to ITA specifications is used. Load backrest is standard.

### **Warning Device Options**

Audible or Visual Alerts

Safety considerations and dangers associated with audible travel alarms and lights include:

- Multiple alarms and/or lights can cause confusion.
- Workers ignore the alarms and/or lights after day-in and day-out exposure.
- Operator may transfer the responsibility for "looking out" to the pedestrians.
- Annoys operators and pedestrians.

### **Other Options Available**

Contact factory for additional options.

*Dimensions and performance data given may vary due to manufacturing tolerances. Performance is based on an average size vehicle and is affected by weight, condition of truck, how it is equipped and the conditions of the operating area. Crown products and specifications are subject to change without notice.*



### **Crown Equipment Corporation**

New Bremen, Ohio 45869 USA

**Tel** 419-629-2311

**Fax** 419-629-3796

[crown.com](http://crown.com)

**You can count on Crown to build lift trucks designed for safe operation, but that's only part of the safety equation. Crown encourages safe operating practices through ongoing operator training, safety-focused supervision, maintenance and a safe working environment. Go to [crown.com](http://crown.com) and view our safety section to learn more.**

Because Crown is continually improving its products, specifications are subject to change without notice.

Crown, the Crown logo, the color beige, the Momentum mark, Access 1 2 3, InfoLink, MonoLift, OnTrac, Work Assist, InfoPoint, Xpress Lower, ThermoAssist, V-Force and Entry Bar are trademarks of Crown Equipment Corporation in the United States and other countries.

Copyright 2011-2020 Crown Equipment Corporation  
SF18533 Rev. 05-20  
Printed in U.S.A.